

HOOVER®

FloorMATE™

The Hard Floor Cleaner

Owner's Manual

English → pp. 1-13

Español → pàg. 15-22

Français → p. 24-31

Thank you for selecting a HOOVER product.

This cleaner was inspected and packaged carefully before being shipped from the factory. If you should happen to need assistance during assembly or operation:

Visit us online at www.hoover.com to find the service outlet nearest you (click on the "Service" button) or

Call **1-800-944-9200** for an automated referral of authorized service outlet locations (U.S. only) or

Call 1-330-499-9499 to speak with a representative in our Consumer Response Center.

PLEASE DO NOT RETURN THIS PRODUCT TO THE STORE.

**Review this manual before
operating cleaner.**

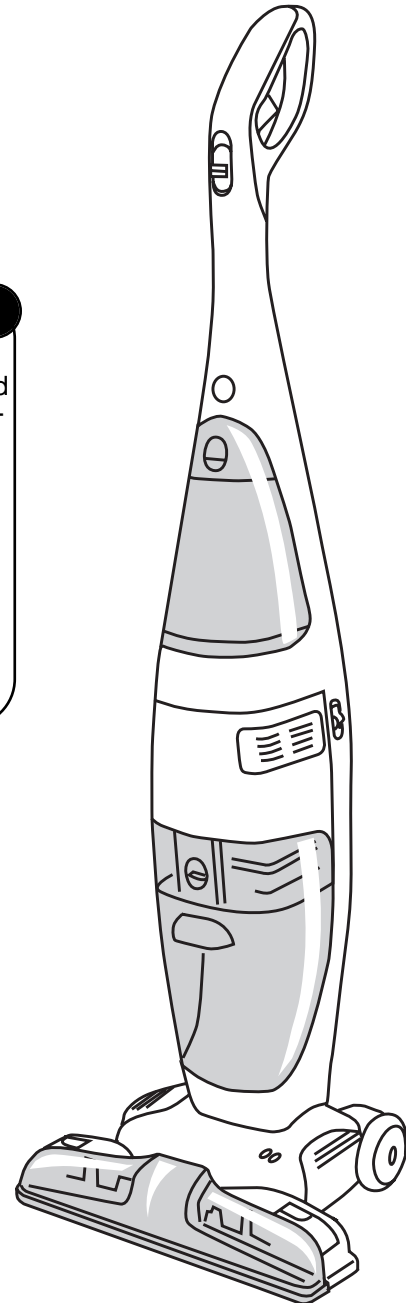

www.hoover.com

Fill in and retain

The model and serial number are located at the bottom of the back of the cleaner body.

For your personal records, please enter the COMPLETE model and serial number in the spaces provided and retain this information.

Your cleaner is model _____

and has serial number _____

It is suggested that you attach your sales receipt to this owner's manual. Verification of date of purchase may be required for warranty service of your Hoover product.

Index

Assembly	3-4
Cleaner descriptions.....	5
How to use.....	5-8
Automatic shut-off	7
General operation	6
Clean solution tank.....	6-7
Recovery tank	7
Storage	11
How to clean.....	9-10
Recommended cleaning sequence.....	9
To clean floor.....	9
Cleaning sealed wood floors ..	10
Picking up spills.....	10
If You Have a Problem	12
Service.....	12
Important Safeguards	2
Maintenance	10-11
Cleaning the brushes	10-11
Cleaning the nozzle.....	11
Warranty	13

© 2003 The Hoover Company
www.hoover.com



Important Safeguards!

When using an electrical appliance, always follow basic precautions, including the following:

READ ALL INSTRUCTIONS BEFORE USING THIS APPLIANCE

Warning:

To reduce the risk of fire, electric shock, or injury:

- Use indoors only.
- Use only on surfaces moistened by the cleaning process or small spills. Do not immerse product.
- For use on bare floors or sealed wood floors. **Not** for use on carpets.
- Always install float before any wet pick up operation.
- Close supervision is necessary when any appliance is used by or near children. Do not allow cleaner to be used as a toy or to run unattended at any time.
- Keep hair, loose clothing, fingers, feet and all parts of body away from openings and all moving parts.
- Do not pick up anything that is burning or smoking, such as cigarettes, matches, or hot ashes.
- Do not pick up or use flammable or combustible materials such as gasoline or fine wood sandings or use in areas where present.
- Avoid picking up hard, sharp objects with the cleaner. They may damage the cleaner.
- Do not put any object into openings. Do not use with any opening blocked; keep free of dust, lint, hair, or anything that may reduce air flow.
- Do not pull or carry by cord, use cord as a handle, close door on cord or pull cord around sharp edges or corners. Do not run appliance over cord. Keep cord away from heated surfaces.
- Always disconnect cord from electrical outlet before servicing the cleaner.
- Unplug cleaner when not in use. Turn off all controls before unplugging.
- Do not unplug by pulling on cord. To unplug, grasp the plug, not the cord. Never handle plug or appliance with wet hands.
- Connect to a properly grounded outlet only. See "Grounding instructions".
- Do not clean over floor electrical outlets.
- Do not use without tanks in place.
- Use extra care when cleaning on stairs. Do not place cleaner on stairs.
- The use of an extension cord is not recommended. If an extension cord is absolutely necessary, use at least a 16 gauge 3-wire cord which has a 3-prong grounding type plug and a 3-pole receptacle that accepts the machine plug.
- Keep detergents and other cleaners out of children's reach.
- Do not pick up chlorine bleach, pine based cleaners, drain cleaner, or any other toxic material with this appliance.
- When using recommended chemicals with this machine, be certain area is well ventilated.
- Follow manufacturer's instructions for all chemicals used with this machine. Do not exceed recommended mixing ratios.
- Store in a dry place. Do not expose machine to freezing temperatures.
- Do not use with damaged cord or plug. If appliance is not working as it should, has been dropped, damaged, left outdoors, or dropped into water, take it to a Hoover Factory Service Center or Authorized Hoover Warranty Service Dealer (Depot).
- Use cleaner only for its intended use as described in the instructions.

Save these instructions!

Questions or Concerns?

The Hoover Company wants to quickly resolve any concerns about your cleaner or questions regarding its use. Look on the list provided with the product for your local **Hoover Factory Service Center** or in the Yellow Pages under "Vacuum Cleaners - Household" for the nearest **Authorized Hoover Warranty Service Dealer** (Depot) or:

Visit us online at www.hoover.com to find the service outlet nearest you (click on the "Service" button) OR

Call **1-800-944-9200** for an automated referral of authorized service outlet locations (U.S. only) OR

Call 1-330-499-9499 to speak with a representative in the Hoover Consumer Response Center.

Call **1-800-228-4722** for questions or comments concerning Machine Formula LYSOL® or OLD ENGLISH® Floor Cleaning Concentrate.

Grounding Instructions

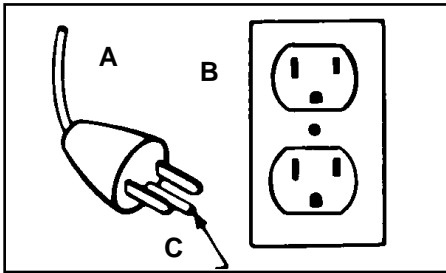

This appliance must be grounded. If it should malfunction or breakdown, grounding provides a path of least resistance for electrical current to reduce the risk of electric shock. This appliance is equipped with a cord having an equipment-grounding conductor (C) and grounding plug (A). The plug must be plugged into an appropriate outlet (B) that is properly installed and grounded in accordance with all local codes and ordinances.

DANGER-

Improper connection of the equipment-grounding conductor can result in the risk of electric shock. Check with a qualified electrician or service person if you are in doubt as to whether the outlet is properly grounded. Do not modify the plug provided with the appliance - if it will not fit the outlet, have a proper outlet installed by a qualified electrician. This appliance is for use on a nominal 120 volt circuit and has a grounding plug that looks like the plug illustrated in sketch (A).

A temporary adapter (D) may be used to connect this plug to a 2-pole receptacle (E) if a properly grounded outlet (B) is not available. The temporary adapter should be used only until a properly grounded outlet (B) can be installed by a qualified

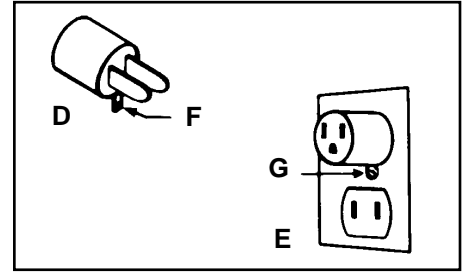

electrician. The green colored rigid ear, lug, or the like (F) extending from the adapter must be connected to a permanent ground (G) such as a properly grounded outlet box cover. Whenever the adapter is used, it must be held in place by a metal screw. **NOTE:** In Canada, the use of a temporary adapter is not permitted by the Canadian Electrical Code.

1. Assembly

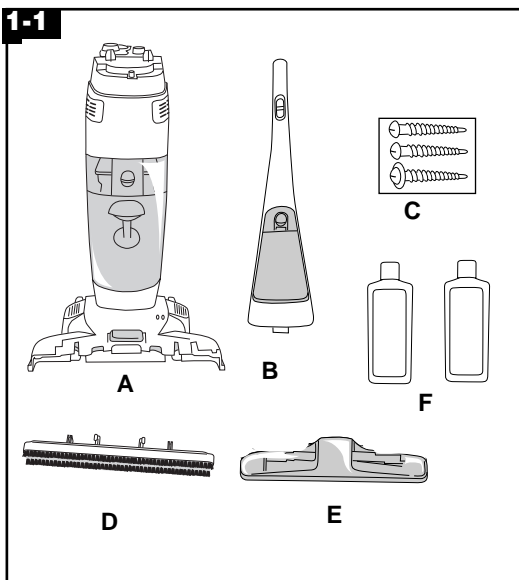

Carton contents

- A. Hard floor cleaner
- B. Upper handle
- C. Screw packet (3 screws-1 with washer)
- D. Brush assembly
- E. Nozzle
- F. Floor cleaning concentrates

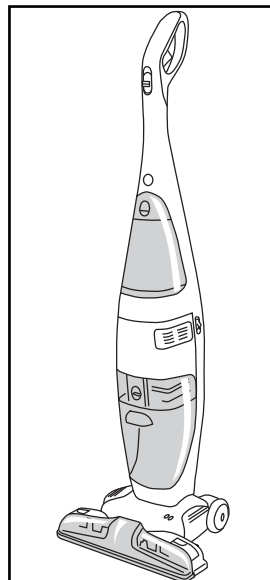

The assembled cleaner will look like this drawing.

This cleaner is intended for household use.

Assemble handle

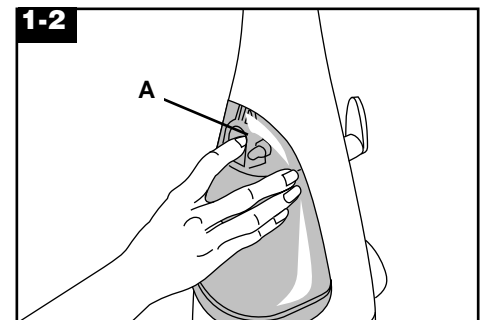

Assemble Handle

Press down on latch (A) and remove clean solution tank from upper handle.

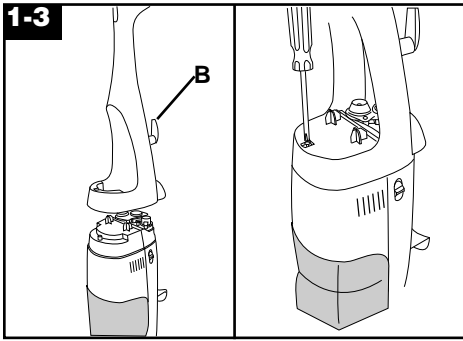

With cord hook (B) to back of cleaner, push upper handle down onto cleaner. Insert screw with washer in front of tank area. Tighten screw with a Phillips screwdriver.

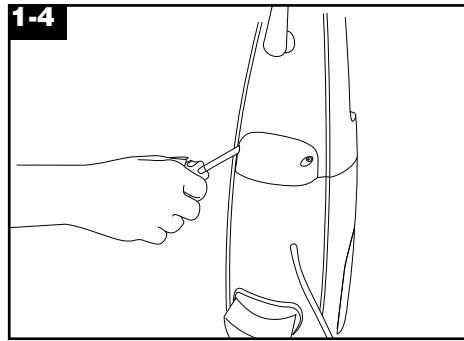

Insert two screws into back of handle as shown. Tighten with a Phillips screwdriver.

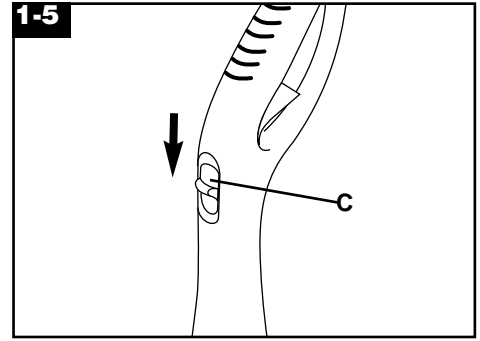

Push brush control switch (C) down to connect switch rod. You will hear a "click" when the switch rod is in place.

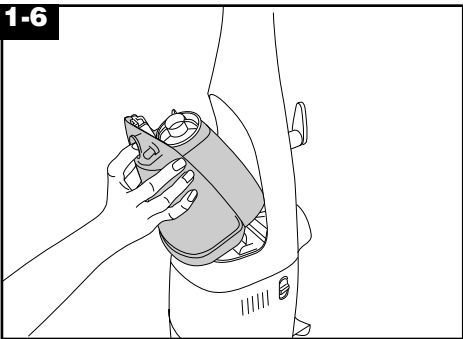

Replace clean solution tank by positioning bottom first. Press latch and snap top portion into place.

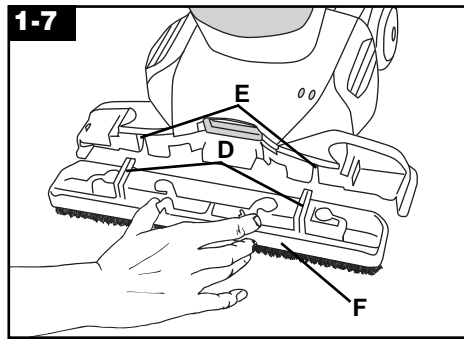

To install brush assembly and nozzle, place handle in upright position. Align tabs (D) on brush assembly with slots (E) in cleaner. Slide brush assembly (F) into place.

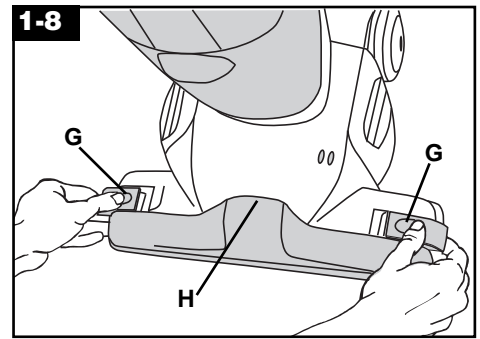

To install nozzle, make sure latches (G) are out. Align middle section (H) of nozzle with opening on cleaner.

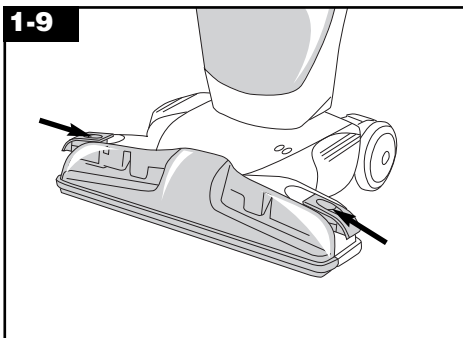

While holding nozzle in place, slide latches inward to lock in place. Remove cardboard packing insert from squeegee area on underside of nozzle.

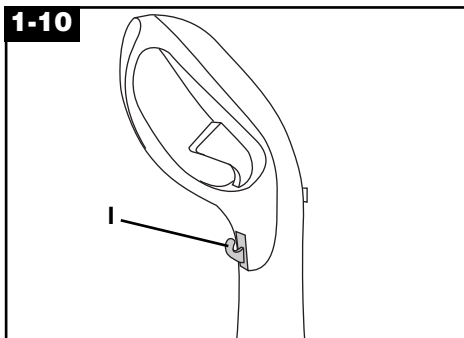

Cord clip

To help keep the cord out of the way while cleaning, position cord down into cord clip (I), located on the handle.

2. How to use

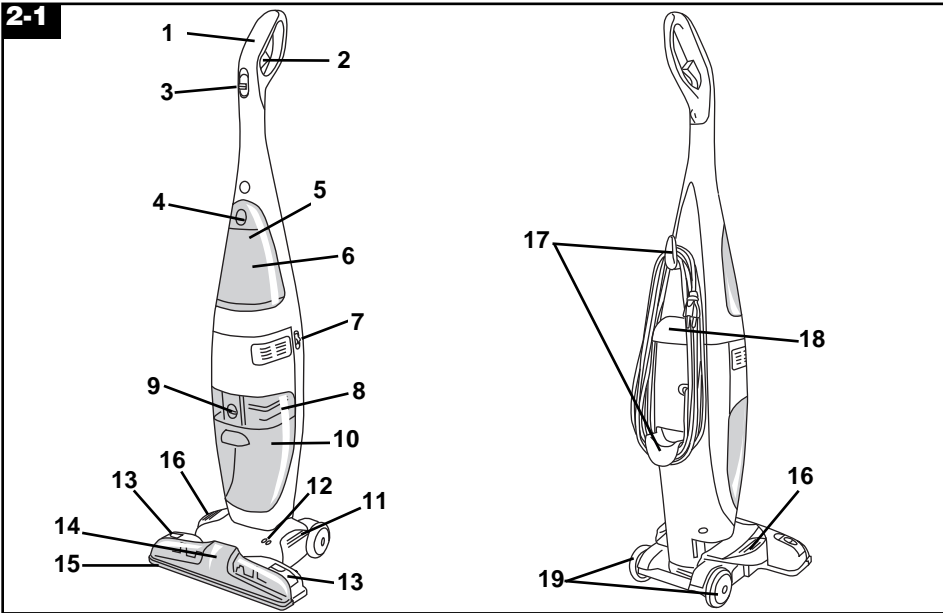

The assembled cleaner will look like this drawing.

1. **Hand grip**
2. **Solution trigger:** squeeze to release clean solution.
3. **Brush control switch:** lowers the brush assembly for wet cleaning or raises the brush assembly for wet pickup and dry vacuuming.
4. **Clean solution tank release**
5. **Clean solution tank cap/measuring cup**
6. **Clean solution tank**
7. **ON/OFF switch**
8. **Recovery tank lid and filter**
9. **Recovery tank release**
10. **Recovery tank:** Collects dry

debris as well as dirty cleaning solution.

11. **Wet/Dry pedal:** Press pedal to change between wet and dry cleaning.
12. **Wet/Dry indicators:** Shows either wet or dry cleaning usage.
13. **Nozzle release buttons:** Release nozzle for easy clean-up.
14. **Nozzle**
15. **Squeegee**
16. **Handle release pedal**
17. **Cord hooks:** Top hook rotates for quick cord release.
18. **Carrying handle**
19. **Soft-tread wheels**

This cleaner is intended for household use.

Operate cleaner only at voltage specified on data plate on back of cleaner.

Plug cleaner into a properly grounded outlet.

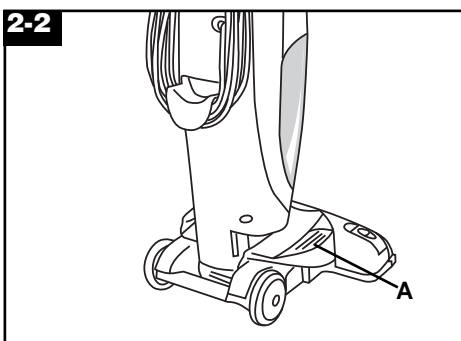

Handle Release Pedal

Step on pedal (A) to lower handle to operating position. Handle does not lock into a single position but "floats" to allow convenient operation.

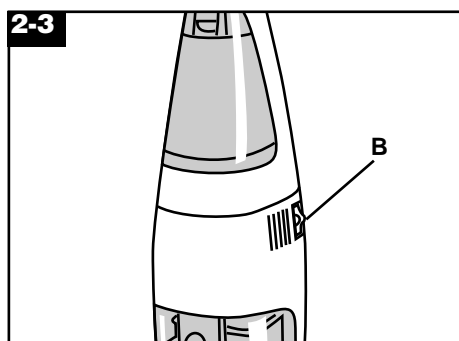

ON/OFF Switch

Push switch (B) up to turn cleaner on. Push switch down to turn cleaner off.

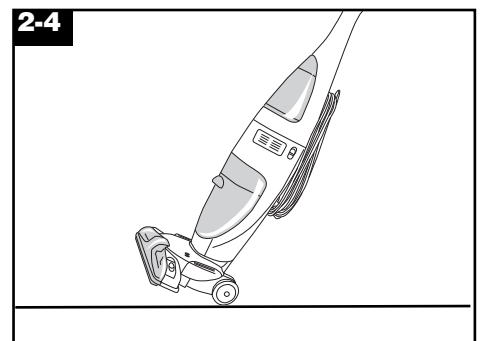

To transport

To move your cleaner from room to room, put handle in upright position; tilt cleaner back on rear wheels and push forward.

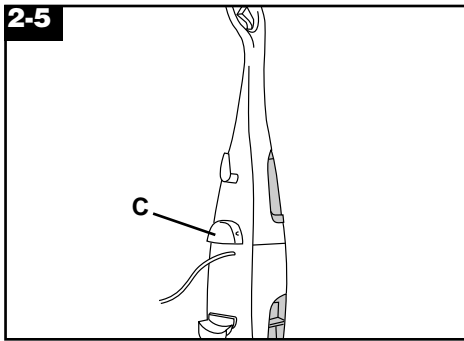

The cleaner may also be lifted using the carrying handle (C) on the back of the cleaner.

General Operation

Your HOOVER FloorMate™ Cleaner can be used to both vacuum dry debris and wet clean non-carpeted floor surfaces such as vinyl, tile and sealed wood. **It is not intended for use on carpet or rugs.**

CAUTION: To prevent damage to wood floors, follow the flooring manufacturer's cleaning recommendations.

If using cleaner on sealed wood floors, inspect floor surface for worn finish, bare wood or separated joints. Do not use 'FloorMate' cleaner to wet clean sealed wood floors if any of these conditions exist.

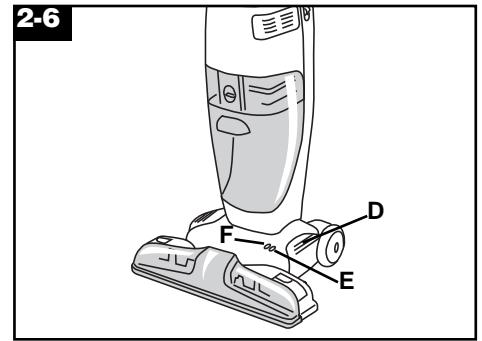

Wet/Dry pedal and indicators

The wet/dry pedal (D) lowers the nozzle squeegee for wet operation and raises it for picking up dry debris.

The WET indicator (E) will show red when pedal is set for wet operation.

The DRY indicator (F) will show red when pedal is set for dry vacuuming.

See "How to clean" section for complete cleaner setup instructions.

Step on pedal to choose either the WET or DRY setting.

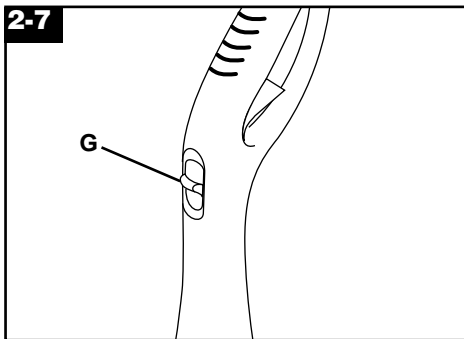

Brush Control Switch

The brush control switch (G) lowers or raises the brush assembly for different types of cleaning.

To wet clean with brush assembly down, push the switch down to the WET SCRUB position.

For wet pickup, push the switch up to the WET/DRY PICKUP position. In this position, the brush assembly will be raised off the floor surface.

For dry debris pickup, push the switch up to the WET/DRY PICKUP position.

See "How to clean" section for complete cleaner setup instructions.

The Tanks

Clean Solution Tank (Upper Tank)

The clean solution tank holds the cleaning solution that is to be dispersed onto the surface to be cleaned.

How to fill

Disconnect cleaner from electrical outlet.

Place cleaner handle in upright, locked position.

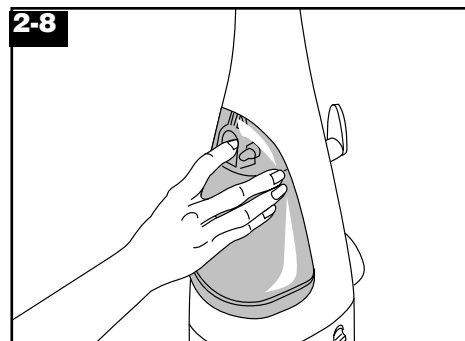

To remove tank, press down on release button and pivot tank forward.

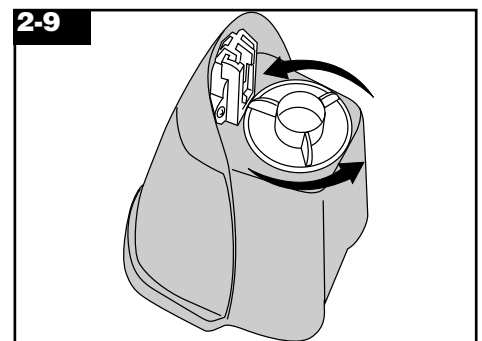

Carry tank to a sink.

Rotate tank cap counter-clockwise and lift up to remove cap.

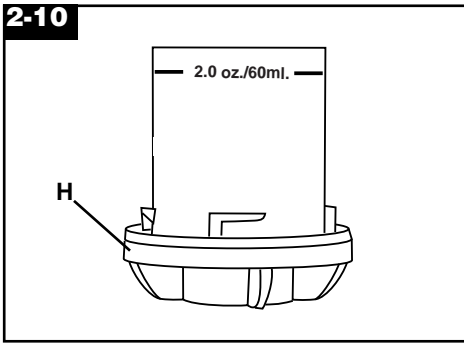

Turn cap (H) upside down to serve as a measuring cup.

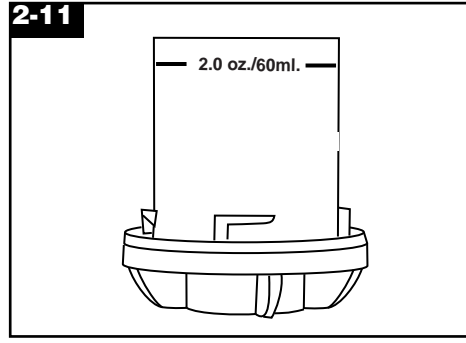

Using cap, measure 2 oz. of applicable concentrate formulated for use with the 'FloorMate' hard floor cleaner.

For best results, use Machine Formula LYSOL® Floor Cleaning Concentrate when cleaning floor surfaces such as vinyl, ceramic and other tiles, and linoleum.

Use Machine Formula OLD ENGLISH® Wood Floor Cleaning Concentrate for wood floors when cleaning laminate wood, polyurethane sealed wood or other wood floors that can normally be cleaned using water.

Check for worn spots or joint separations before using, as these conditions could lead to damaged flooring when using water to clean floor.

Both of these concentrates have been specifically formulated to resist excessive foaming and other undesirable effects when used in your 'FloorMate' cleaner.

DO NOT use cleaning concentrates that contain pine or solvent based ingredients.

CAUTION: Machine Formula LYSOL® Floor Cleaning Concentrate and OLD ENGLISH® Wood Floor Cleaning Concentrate cannot be used in Hoover SteamVac™ products. Doing so could damage your SteamVac™.

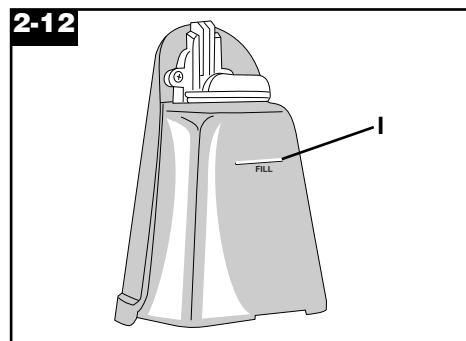

Pour cleaning concentrate into tank. Fill tank to fill line (I) (1 quart) with warm water.

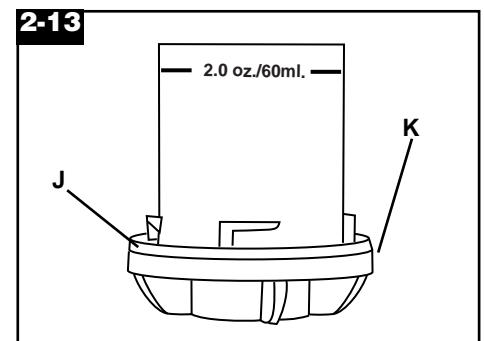

If rubber ring (J) on cap has become dislodged, reposition it with uneven side against ledge (K) as shown.

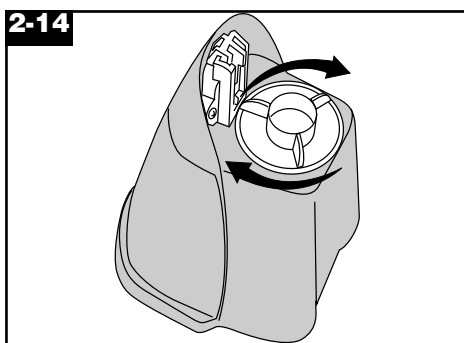

Replace cap. Rotate cap clockwise until it locks in place. Cap must be locked in place for proper performance and to prevent leaking.

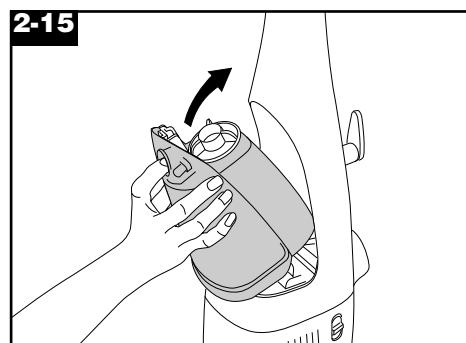

Position bottom of tank into cleaner. Press latch and snap tank into place.

Recovery Tank (lower tank)

The recovery tank holds both dry debris and dirty cleaning solution that is picked up from the floor surface.

Automatic Shut-Off

An automatic suction shut-off is built into the recovery tank to prevent the tank from overflowing.

When the shut-off activates, the cleaner will not pick up debris and the sound of the motor will change.

There are two reasons the shut-off will activate.

- 1. Recovery tank is full** - Turn the cleaner off and empty the recovery tank.
- 2. The handle was raised to the upright position while the motor was running** - Turn cleaner off. Wait a moment for the shut-off to reset. Turn cleaner on and continue cleaning.

How to Empty

Turn cleaner off and disconnect from electrical outlet.

Although not necessary for satisfactory performance, it is recommended that the recovery tank be emptied after dry vacuuming and before wet operation.

Check the solution tank also. It may need to be refilled at this time.

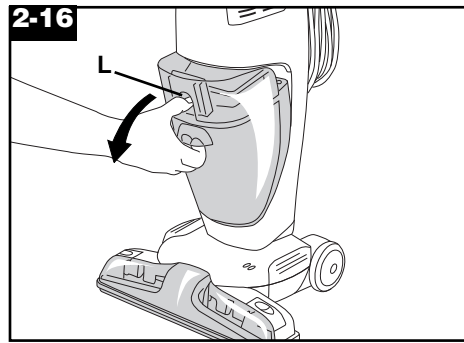

To remove tank, press down on release button (L) and pivot tank forward.

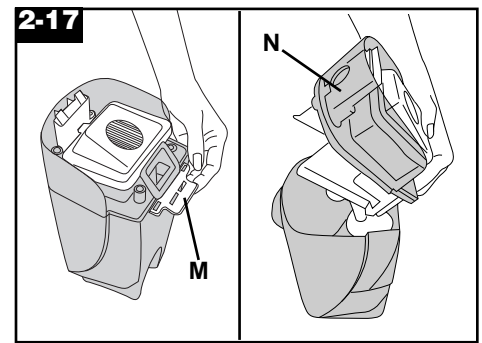

Lift up on tank lid latch (M) and remove the tank lid (N). Empty tank.

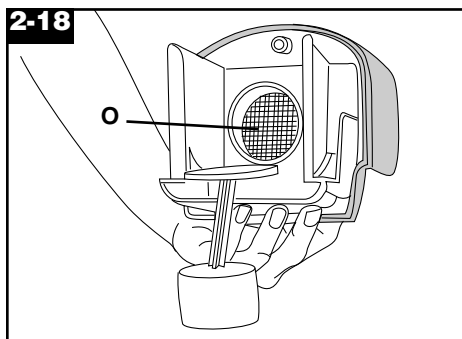

Dry or loose debris will also collect on the filter screen (O) in the tank lid. Remove debris from screen.

The filter screen may also be cleaned by rinsing it under running water.

The tank lid contains a washable, reusable filter. Clean this filter when suction is low or reduced (Figs. 2-21 and 2-22).

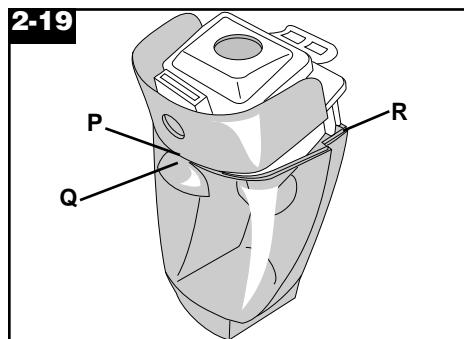

To replace lid, align tab (P) on lid with hole on front of tank (Q).

Snap latch over tabs (R) on back of tank.

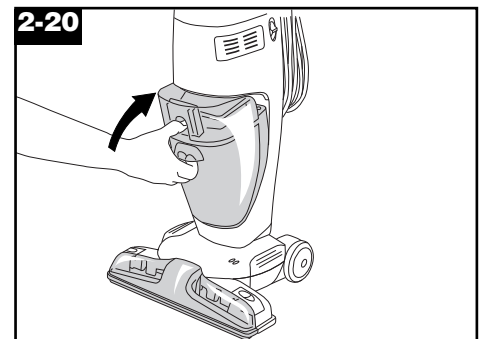

To replace tank, insert bottom of tank into cleaner and pivot top portion until it is locked in place.

To Clean Filter

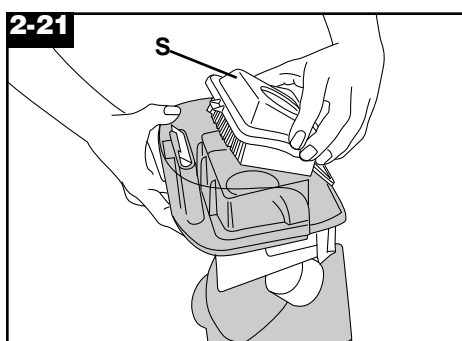

Turn cleaner OFF and disconnect from electrical outlet.

Remove recovery tank and lid (Fig. 2-16 & 2-17). Remove filter lid (S), then remove filter. Remove loose debris from filter by either brushing or tapping the filter. The filter may also be rinsed for additional cleaning. Allow filter to air dry between uses.

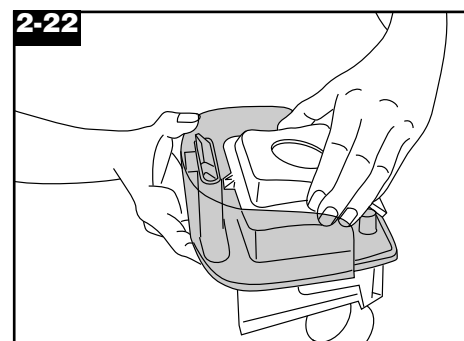

Replace filter lid. Press down firmly to secure the seal.

3. How to clean

Recommended Cleaning Sequence

Use your HOOVER 'FloorMate' Cleaner to:

1. **Dry Vacuum** to remove loose dirt, hair and debris.
2. **Wet Clean** the floor surface.
3. **Wet Pickup** reduces drying time of the floor surface.

Follow the chart to set the controls for each cleaning step.

OPERATION	BRUSH CONTROL SWITCH	WET/DRY PEDAL
Dry Vacuuming	"Wet/Dry Pickup" (UP)	Dry Pickup
Wet Cleaning	"Wet Scrub" (DOWN)	Wet Pickup/Scrub
Wet Pickup	"Wet/Dry Pickup" (UP)	Wet Pickup/Scrub
See Page 6 Figs. 2-6 and 2-7 for complete instructions on the control switch and pedal.		

To Clean Floor (vinyl, tile, linoleum, etc.)

1. Set cleaner for Dry Vacuuming operation and vacuum floor. (See chart on page 9.)
2. Empty Recovery Tank. (Figs. 2-16 through 2-20).
3. Fill solution tank with Machine Formula LYSOL® Floor Cleaning Concentrate and water, according to instructions for Figs. 2-8 through 2-12. **Do not use pine or solvent based cleaning concentrates in your cleaner. Do not use any type of wax in your cleaner.**
4. Set cleaner controls for "Wet Cleaning" operation. (See chart on page 9.)
5. Dry hands and **plug cleaner into a properly grounded outlet.**

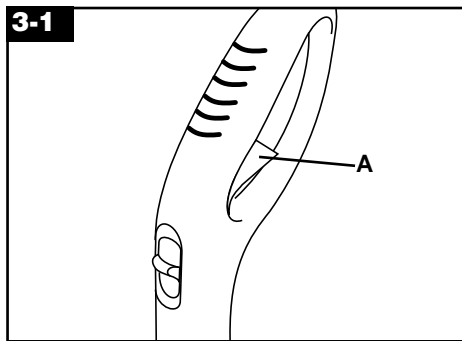

6. Step on handle release pedal and lower handle to operating position; turn cleaner ON.
7. To release solution, squeeze trigger (A). Slowly move cleaner forward and backward over area to be cleaned. Squeeze trigger to release solution as needed.
- Overlap strokes by one inch to help prevent streaking.

The cleaner's suction will pick up the dirty solution throughout cleaning.

8. **To greatly enhance drying of the floor surface**, release trigger and move wet control switch up to the "WET/DRY PICKUP" setting. Continue to move cleaner over the area to pick up the dirty solution.

9. To continue cleaning another area, move wet control switch down to "WET Scrub". Repeat with steps 7-9.

NOTE: When switching between wet cleaning and wet pickup, it is not necessary to turn the cleaner off. Simply move the control switch back and forth between the two settings.

10. Empty recovery tank or clean the filter when the motor sound becomes higher in pitch and there is a loss of suction (see "Automatic Shut-Off", page 7).

Cleaning Sealed Wood Floors

Your HOOVER 'FloorMate' Cleaner may be used to clean wood floors that have been sealed with a polyurethane coating and can be cleaned with water.

CAUTION: To prevent damage to wood floors, follow the flooring manufacturer's cleaning recommendations.

If using cleaner on sealed wood floors, inspect floor surface for worn finish, bare wood or separated joints. Do not use 'FloorMate' cleaner to wet clean sealed wood floors if any of these conditions exist.

1. Inspect floor surface for worn finish, bare wood or separated joints. Do not use your 'FloorMate' cleaner to wet clean the floor if any of these conditions exist.

2. Set cleaner for Dry Vacuuming operation and vacuum floor (see chart on Page 9).

3. Empty recovery tank (Figs. 2-16 through 2-20).

4. Fill solution tank with Machine Formula OLD ENGLISH® Wood Floor Cleaning Concentrate and water, according to instructions for Figs. 2-8 through 2-12.

Do not use pine or solvent based detergents. Do not put any type of wax in your cleaner.

5. Set cleaner controls for "Wet" Cleaning (see chart page 9).

6. Dry hands and **plug cleaner in to a properly grounded outlet.**

7. Step on handle release pedal and lower handle to operating position; turn cleaner ON.

8. Push cleaner forward, squeeze trigger while pulling cleaner backward. Release trigger and push cleaner forward. Continue cleaning floor surface while releasing solution on the backward strokes only. This will allow for effective cleaning with small amounts of solution.

Overlap strokes by 1 inch to help prevent streaking.

9. **To greatly enhance drying of the floor surface**, release trigger and move wet control switch to the "WET PICKUP" setting.

10. To continue cleaning, move wet control switch down to "WET Scrub". Repeat steps 7 – 9. **Make sure all areas are completely dry. Ensure that no water remains on the floor.**

NOTE: When switching between wet cleaning and wet pickup, it is not necessary to turn the cleaner off. Simply move the control switch back and forth between the two settings.

11. Empty the recovery tank or clean the filter when the motor sound becomes higher in pitch and there is a loss of suction (see "Automatic Shut-Off", Page 7).

Picking Up Spills

Your cleaner may also be used to pick up **small liquid spills (1 quart or less, never to exceed 1/4 inch in depth)** on non-carpeted floors.

Set Wet/Dry pedal in the WET Pickup/Scrub position.

Set Wet Control switch to the "WET/DRY Pickup" position.

Do not use the cleaner to pick up flammable or combustible liquids or chemicals. Do not use the cleaner to pick up detergents that contain pine or solvent based ingredients.

4. Maintenance

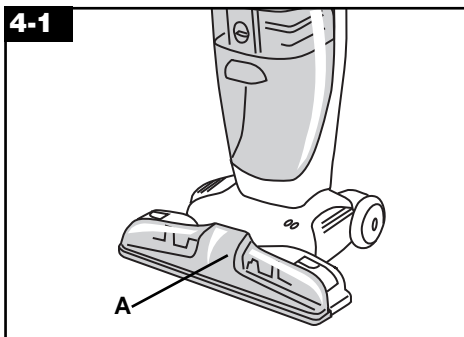

Cleaning the Nozzle

Turn cleaner OFF and disconnect from electrical outlet.

The cleaner's nozzle (A) can be removed for easy cleaning.

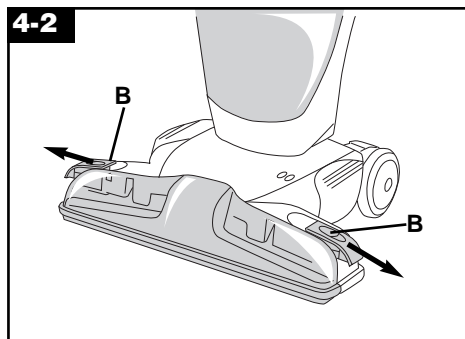

Slide the two nozzle release latches (B) outward.

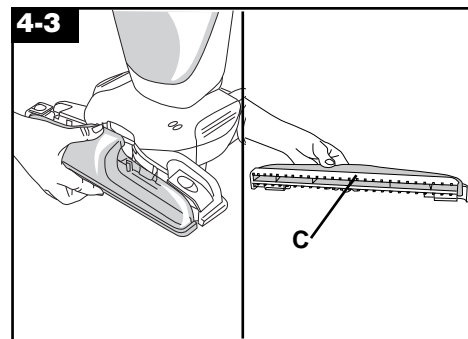

Remove the nozzle by pulling straight out.

Rinse nozzle under running water. Remove debris from squeegee (C) and wipe with a damp cloth.

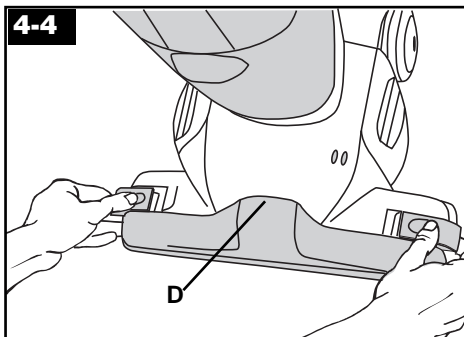

To replace nozzle, make sure latches are out. Align middle section (D) of nozzle with opening on cleaner.

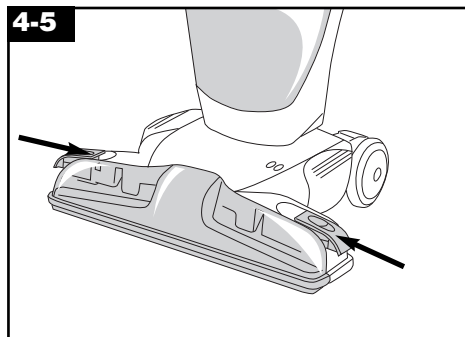

While holding nozzle in place, slide latches inward to lock in place.

Cleaning the brushes

Turn cleaner OFF and disconnect from electrical outlet.

The brush assembly can be removed for easy cleaning.

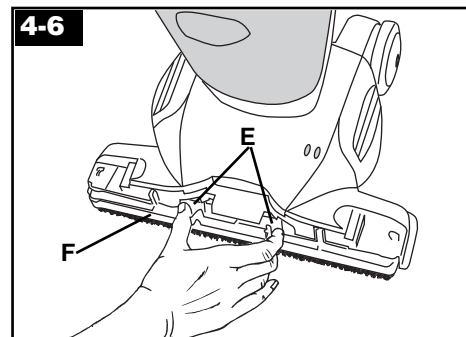

Remove nozzle as described in Fig. 4-1 through 4-3.

Using finger grips (E) on the brush assembly (F), pull straight out.

The brush assembly can be washed with a mild detergent and rinsed. Do not use pine or solvent-based detergents.

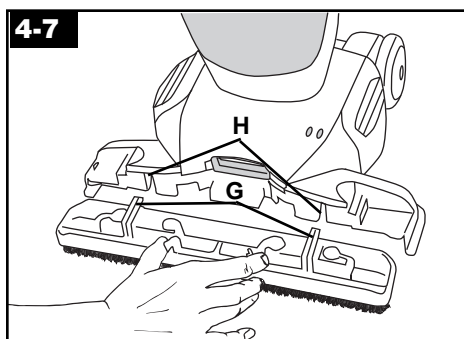

Align tabs (G) on brush assembly with slots (H) in cleaner.

Slide brush assembly into place.

Replace nozzle as described in Figs. 4-4 and 4-5.

Storage

Before storing cleaner:

Turn cleaner OFF and disconnect from electrical outlet.

- Empty and rinse solution and recovery tanks. Allow to air dry.
- Allow filter in recovery tank lid to dry.
- Set the cleaner for "Dry Vacuuming" (pedal to "DRY" and Wet Control switch up).
- Make sure that nothing is pressing on the nozzle squeegee.
- Do not store cleaner on a wood surface unless cleaner is **completely** dry.

5. If you have a problem

If a minor problem occurs, it usually can be solved quite easily when the cause is found by using the check list below.

Problem: Machine won't run

Possible cause

Possible solution

- **Not firmly plugged in**
 - Plug unit in firmly.
- **No voltage in wall receptacle**
 - Check fuse or breaker.
- **Blown fuse/tripped breaker**
 - Replace fuse/reset breaker.

Problem: Low or no suction

Possible cause

Possible solution

- **Automatic shut-off activated**
 - Turn cleaner OFF and then ON again or
 - Empty recovery tank (see "Automatic shut-off" section)
- **Filter or filter lid missing or not positioned correctly**
 - Ensure that filter and filter lid are properly positioned in the recovery tank lid (Fig. 2-22)
- **Recovery tank and/or solution tank not positioned properly**
 - Ensure that both tanks are locked in place.
- **Filter is dirty**
 - Clean filter
- **Nozzle not properly positioned**
 - Ensure nozzle is replaced properly and locked (Figs. 4-4 & 4-5).

Problem: Water puddling behind cleaner

Possible cause

Possible solution

- **Excess cleaning concentrate foaming in tanks**
 - Use Machine Formula LYSOL® Floor Cleaning Concentrate or Machine Formula OLD ENGLISH® Wood Floor Cleaning Concentrate, it is a low-foam formulation. If using cleaning concentrate other than LYSOL® brand or OLD ENGLISH® brand, remix cleaning solution using less concentrate.
- **Solution tank not properly installed**
 - Ensure that tank is installed properly (Fig. 2-15).
- **Recovery tank is full**
 - Empty tank

Problem: Cleaner does not pick up dirty solution

Possible cause

Possible solution

- **Cleaner not set for wet operation**
 - Press wet/dry pedal to "WET" position.
- **Recovery tank not properly installed**
 - Ensure that recovery tank is installed properly (Fig. 2-20).
- **Recovery tank full/automatic shut-off engaged.**
 - Remove and empty recovery tank.
- **Filter or filter lid missing or not properly positioned.**
 - Ensure recovery tank filter and filter lid are properly installed (Fig. 2-22).

Problem: Cleaner pushes a line of dry debris in front of it

Possible cause

Possible solution

- **Cleaner not set for dry operation**
 - Press wet/dry pedal to "DRY PICK-UP" position.
- **Debris is too large to clear squeegee**
 - Tip nozzle off floor by pushing down on handle.

Problem: Clean solution won't dispense

Possible cause

Possible solution

- **Solution tank not firmly in place**
 - Make sure tank is securely locked in position.
- **Solution tank empty**
 - Refill solution tank.
- **Brush assembly channels clogged**
 - Remove brush assembly (Figs. 4-1 through 4-3 and 4-6 through 4-7) and clean channels (A) by running under warm tap water.

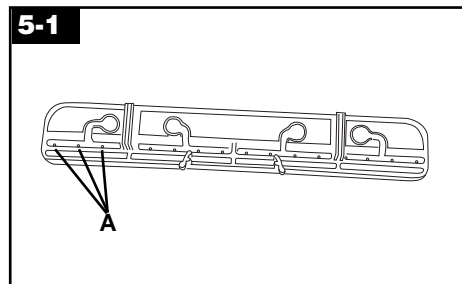

Service

To obtain approved HOOVER service and genuine HOOVER parts, locate the nearest **Hoover Factory Service Center or Authorized Hoover Warranty Service Dealer (Depot)** by:

- checking the Yellow Pages under "Vacuum Cleaners - Household" OR -
- checking the list of Factory Service Centers provided with this cleaner OR -
- checking the Service section of The Hoover Company on-line at **www.hoover.com** OR -
- calling **1-800-944-9200** for an automated referral of authorized service outlet locations (U.S. only).

Do not send your cleaner to The Hoover Company in North Canton for service, this will only result in delay.

If further assistance is needed, contact The Hoover Company Consumer Response Center, North Canton, Ohio 44720 Phone: 1-330-499-9499.

In Canada, contact Hoover Canada, Burlington, Ontario L7R 4A8, Phone: 1-800-263-6376.

Always identify your cleaner by the **complete** model number when requesting information or ordering parts. (The model number appears at the bottom of the back of the cleaner body.)

For questions or comments concerning Machine Formula LYSOL® or OLD ENGLISH® Floor Cleaning Concentrate, call **1-800-228-4722**.

LYSOL and OLD ENGLISH are registered trademarks of Reckitt Benckiser Inc.

Full One Year Warranty (Domestic Use)

Your HOOVER® appliance is warranted in normal household use, in accordance with the Owner's Manual against original defects in material and workmanship for a period of one full year from date of purchase. This warranty provides, at no cost to you, all labor and parts to place this appliance in correct operating condition during the warranted period. This warranty applies when the appliance is purchased in the United States including its territories and possessions, or in Canada or from a U. S. Military Exchange. Appliances purchased elsewhere are covered by a limited one year warranty which covers the cost of parts only. This warranty does not apply if the appliance is used in a commercial or rental application.

Warranty service can only be obtained by presenting the appliance to one of the following authorized warranty service outlets. Proof of purchase will be required before service is rendered.

1. Hoover Factory Service Centers.
2. Hoover Authorized Warranty Service Dealers (Depots).

**For an automated referral of authorized service outlets in the U.S.A.,
phone 1-800-944-9200 OR**

**Visit The Hoover Company on-line at
www.hoover.com**

This warranty does not cover pick up, delivery, or house calls; however, if you mail your appliance to a Hoover Factory Service Center for warranty service, transportation will be paid one way.

While this warranty gives you specific legal rights, you may also have other rights which vary from state to state.

If further assistance is needed, or if there are questions concerning this warranty or the availability of warranty service outlets, write or phone the Consumer Response Center, The Hoover Company, 101 East Maple St., North Canton, Ohio 44720. Phone 1-330-499-9499.

In Canada, contact Hoover Canada, Burlington, Ontario L7R 4A8, 1-800-263-6376.

